特点 Features:

- 小型大容量继电器, 最适合用于马达, 压缩机控制。
Miniature with high switching capability .
especially suit for motor and compressor control.
- 快装端子, 可提供PCB端子型号
Quick connect terminal or PCB terminal available.

触点参数 CONTACT DATA

型号	Model	YX212
触点形式	Contact Arrangement	1A
接触电阻	Contact Resistance	100mΩ Max.
触点材料	Contact Material	银合金 Silver Alloy
额定负载 (阻性)	Contact Rating (Res.Load)	25A 250VAC/30VDC
最大切换电流	Max. Switching Current	30A
最大切换电压	Max. Switching Voltage	277VAC
最大切换功率	Max. Switching Power	7500VA
机械寿命	Mechanical endurance	1x10 ⁷ 次 OPS
电气寿命	Electrical endurance	1x10 ⁵ 次 OPS

性能参数 CHARACTERISTICS

吸合时间 (额定电压下)	Operate Time (at nomi.volt.)	20ms Max.
释放时间 (不带二极管)	Release Time (without diode)	10ms Max.
绝缘电阻	Insulation Resistance	1000MΩ Min.(500VDC)
介质耐压	Dielectric Strength	触点与触点间 Between Open Contacts : 1,000VAC, 50/60Hz 1 min.
		触点与线圈间 Between Coil & Contacts : 4,500VAC, 50/60Hz 1 min.
抗振性	Vibration resistance	误动作 Functional: 10~55Hz 双振幅 1.5mm (DA)
		耐久 Destructive: 10~55Hz 双振幅 1.5mm (DA)
抗冲击	Shock resistance	误动作 Functional: 10G Min.
		耐久 Destructive: 100G Min.
环境温度	Ambient Temperature	-40°C~+105°C (不冷凝 No condensation)
重量	Unit Weight	约 Approx. 22g

线圈参数 COIL DATA (at 23°C)

额定电压 Rated voltage (VDC)	额定电流 Rated current ±10%(mA)	线圈电阻 Coil resistance ±10%(Ω)	最大连续外加电压 Max allowable voltage VDC (Max.)	吸合电压 Operate voltage VDC (Max.)	释放电压 Release voltage VDC (Min.)	额定功率 Rated coil power (W)
5	180.0	28	额定电压的 of rated voltage 130 %	额定电压的 of rated voltage 75 %	额定电压的 of rated voltage 5 %	约 approx. 0.9
6	150.0	40				
9	100.0	90				
12	75.0	160				
18	50.0	360				
24	37.5	640				
36	25.0	1,440				
48	18.8	2,560				

线圈参数 COIL DATA (at 23°C)

额定电压 Rated voltage (VDC)	额定电流 Rated current ±10%(mA)	线圈电阻 Coil resistance ±10%(Ω)	最大连续外加电压 Max allowable voltage VDC (Max.)	吸合电压 Operate voltage VDC (Max.)	释放电压 Release voltage VDC (Min.)	额定功率 Rated coil power (W)
5	280.0	18	额定电压的 of rated voltage 130 %	额定电压的 of rated voltage 75 %	额定电压的 of rated voltage 5 %	约 approx. 1.4
6	233.3	26				
9	155.6	58				
12	116.7	103				
18	77.8	231				
24	58.3	411				
36	38.9	926				
48	29.2	1,646				

订货标记示例 ORDERING INFORMATION

YX212	-S	-1	12	D	M	P	X	
特殊参数 Special parameters: 无-标准型, 字母或数字-特殊要求								
端子形式 Terminal form: 无-标准型, P-PCB端子 Nil-Standard, P-PCB								
触点形式 Contact form: M-常开 M-Form A								
线圈功耗 Coil power: D-0.9 W (1.4W 可选 optional)								
线圈规格 Coil voltage: 05,06,09,12,18,24 (VDC)								
触点组数 Number of poles: 1-1组 1-1 Group								
封装形式 Protective construction: S-塑封式 S-Flux proofed								
基本型号 Type designation: YX212								

外形尺寸、接线图、安装孔位图 (单位: mm)

OUTLINE DIMENSIONS, WIRING DIAGRAM AND PCB LAYOUT (Unit: mm)

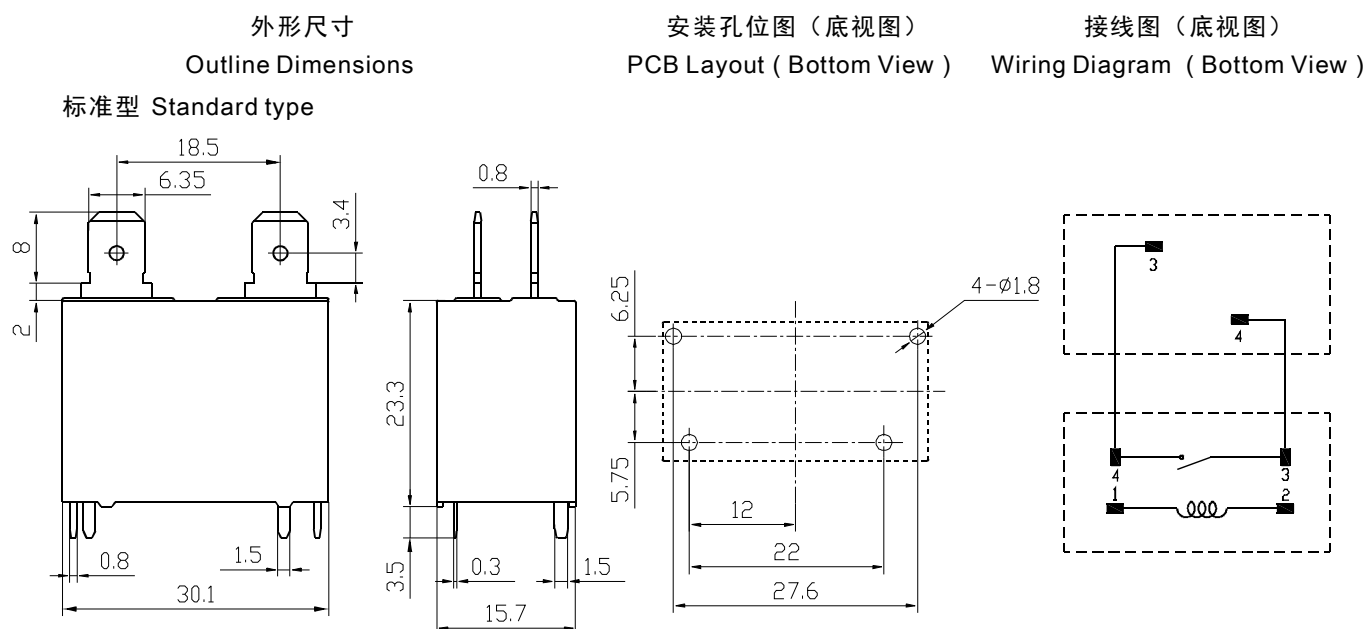

注 Remark :

- 1.未标注尺寸公差 Unmarked dimensional tolerance
≤1mm: ±0.2mm ; (1~5)mm: ±0.3mm ; ≥5mm: ±0.4mm.
- 2.安装孔尺寸公差: ±0.1mm.
The tolerance of PCB layout is always: ±0.1mm.
- 3.引出脚尺寸为预焊前尺寸.
Extended terminal dimension is dimension before soldering.

外形尺寸、接线图、安装孔位图 (单位: mm)

OUTLINE DIMENSIONS, WIRING DIAGRAM AND PCB LAYOUT (Unit: mm)

外形尺寸
Outline Dimensions

安装孔位图 (底视图)
PCB Layout (Bottom View)

接线图 (底视图)
Wiring Diagram (Bottom View)

PCB-标准型 PCB standard

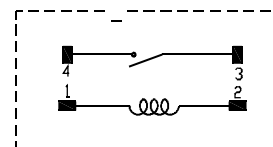
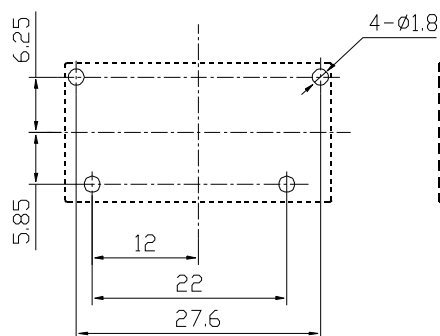
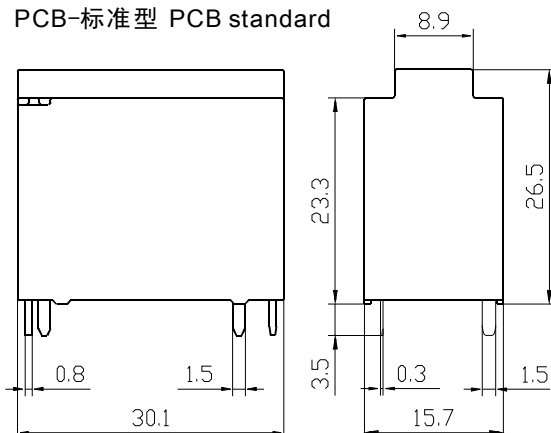

PCB-宽脚型 PCB wide foot type

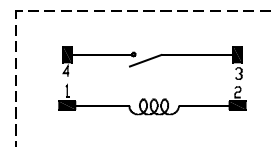
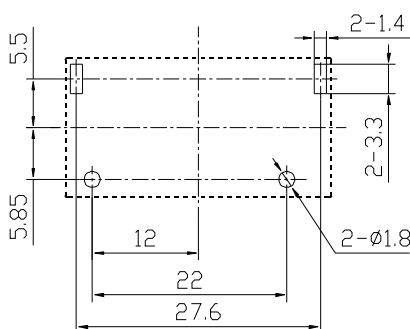
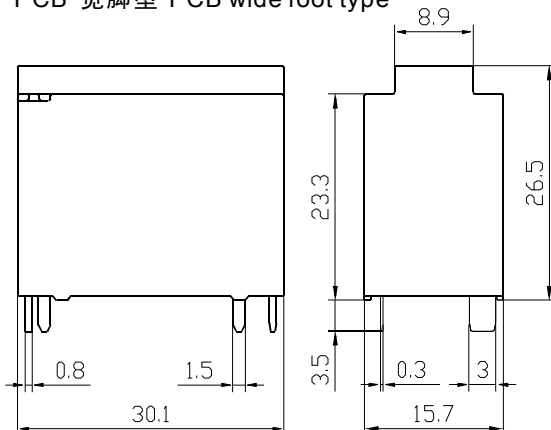

注 Remark :

- 1.未标注尺寸公差 Unmarked dimensional tolerance
 $\leq 1\text{mm}$: $\pm 0.2\text{mm}$; $(1\sim 5)\text{mm}$: $\pm 0.3\text{mm}$; $\geq 5\text{mm}$: $\pm 0.4\text{mm}$.
- 2.安装孔尺寸公差: $\pm 0.1\text{mm}$.
 The tolerance of PCB layout is always: $\pm 0.1\text{mm}$.
- 3.引出脚尺寸为预焊前尺寸.
 Extended terminal dimension is dimension before soldering.

性能曲线图 CHARACTERISTIC CURVES

最大切换功率
Max. Switching Power

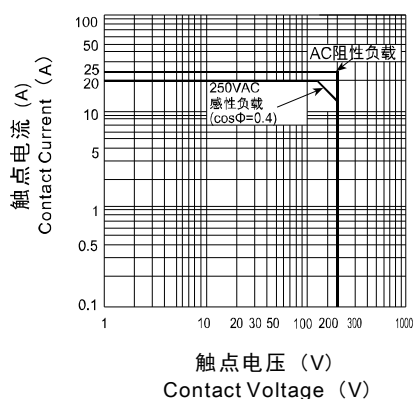

寿命曲线
Endurance Curve

